

MAXIM

MAX3665 Evaluation Kit

Evaluates: MAX3665

General Description

The MAX3665 evaluation kit (EV kit) simplifies evaluation of the MAX3665 transimpedance preamplifier. The EV kit includes a circuit that emulates the zero-to-peak current input signal that would be produced by a photodiode. It also includes a calibration circuit that allows accurate bandwidth measurements.

The MAX3665 EV kit is fully assembled and tested.

Component List

| DESIGNATION | QTY | DESCRIPTION |
|--------------------------|-----|---|
| C1, C2, C4, C7, C10, C11 | 6 | 1000pF $\pm 10\%$, 25V min ceramic capacitors |
| C3, C5, C6, C12–C16 | 8 | 0.1 μ F 10%, 10V min ceramic caps |
| C8, C9 | 2 | 33 μ F $\pm 10\%$, 16V min tantalum caps AVX TAJC336K016 |
| C17, C20, C23 | 3 | 5pF ± 0.1 pF, 50V capacitors |
| C18, C19, C21 | 3 | 4pF ± 0.1 pF, 50V capacitors |
| J1–J5 | 5 | SMA connectors (edge mount) |
| J11–J14 | 4 | Open |
| JU1, JU2 | 2 | 2-pin headers (0.1in centers) |
| L1, L2 | 2 | Ferrite beads Murata BLM11HA601S |
| L3–L8 | 6 | 22nH $\pm 5\%$ inductors |
| R1, R9 | 2 | 2k Ω $\pm 1\%$ resistors |
| R2, R4, R10, R12 | 4 | 1k Ω $\pm 1\%$ resistors |
| R3, R11 | 2 | 49.9 Ω $\pm 5\%$ resistors |
| R5 | 1 | 1k Ω potentiometer |
| R6, R8 | 2 | 10k Ω $\pm 5\%$ resistors |
| R7 | 1 | 10k Ω potentiometer |
| U1 | 1 | MAX3665EUA (8-pin μ MAX) |
| U2 | 1 | CMPT3906 PNP transistor |
| U3 | 1 | MAX400CSA (8-pin SO) |
| U4, U5 | 0 | User-supplied optical modules |
| VCC, +15V, GND | 3 | Test points |
| None | 2 | Shunts for JU1, JU2 |
| None | 1 | MAX3665 evaluation kit (rev B) circuit board |
| None | 1 | MAX3665 data sheet |

Features

- ◆ Fully Assembled and Tested
- ◆ Includes Photodiode Emulation Circuit
- ◆ Calibration Circuit for Accurate Bandwidth Measurements

Ordering Information

| PART | TEMP. RANGE | IC PACKAGE |
|--------------|----------------|-------------|
| MAX3665EVKIT | -40°C to +85°C | 8 μ MAX |

Component Suppliers

| SUPPLIER | PHONE | FAX |
|-----------------------|--------------|--------------|
| AVX | 843-444-2863 | 843-626-3123 |
| Central Semiconductor | 516-435-1110 | 516-435-1824 |
| Murata | 770-684-7821 | – |
| Zetex | 516-543-7100 | 516-864-7630 |

Note: Please indicate that you are using the MAX3665 when contacting these component suppliers.

Quick Start

- 1) Connect a signal source to INPUT. Set the signal amplitude to 50mVp-p (this may require some attenuation between the source and the MAX3665 EV kit). The signal should have a data rate up to 622Mbps.
- 2) Connect OUT+ and OUT- to the 50 Ω inputs of a high-speed oscilloscope.
- 3) Remove shunts from jumpers JU1 and JU2.
- 4) Connect a +3.3V or +5.0V supply to the VCC terminal and ground to the GND terminal.
- 5) The differential signal at the oscilloscope should be between 100mVp-p and 150mVp-p.

Detailed Description

The MAX3665 is designed to accept a DC-coupled input from a photodiode with an amplitude up to 450 μ A peak-to-peak. Because the MAX3665 provides a DC bias for the photodiode, it cannot be DC-coupled to signal sources. To allow characterization without a photodiode, the MAX3665 EV kit provides a simple circuit that emulates a photodiode using common voltage output signal sources.

MAX3665 Evaluation Kit

The connector at INPUT is terminated with 50Ω to ground. This voltage is then AC-coupled to a resistance in series with the MAX3665's input, creating an input current. U2 and U3 form a simple DC current source that is used to apply a DC offset to the input signal.

The values of the series resistive elements, R1 and R2, have been carefully selected so as not to change the bandwidth of the transimpedance amplifier. Surface-mount resistors have parasitic capacitance that reduces their impedance at frequencies above 1GHz. The user should carefully evaluate any changes to R1 and R2 using the calibration network provided on the EV kit.

Photodiode Emulation

The following procedure can be used to emulate the high-speed current signal generated by a photodiode:

- 1) Select the desired optical power (P_{AVG} in dBm) and extinction ratio (r_e).
- 2) Calculate the average current (I_{AVE} in Amps) as follows, and adjust R7 and R5 to obtain it:

$$I_{AVG} = \frac{10^{(P_{AVG}/10)}\rho}{1000}$$

where ρ = photodiode responsivity in A/W.

- 3) Calculate the AC signal current (I_{INPUT} in Amps) as follows, and adjust the signal generator to obtain it:

$$I_{INPUT} = 2 \cdot I_{AVG}(r_e - 1) / (r_e + 1)$$

For example:

- 1) Emulate a signal with an average power of -20dBm and an extinction ratio of 10.
- 2) -20dBm optical power will produce 10μA of average input current (assume photodiode responsivity of 1A/W). Install a current meter at JU1. Adjust R7 and R5 until the current is 10μA.
- 3) The signal amplitude is $I_{AVG}(r_e - 1) / (r_e + 1) = 16\mu\text{A}$. To generate this current through the 3000Ω input resistors, set the signal source to produce an output level of $16\mu\text{A} \cdot 3000\Omega = 48\text{mVp-p}$.

Noise Measurement

Remove R2 before attempting noise measurements to minimize input capacitance. With R2 removed, the total capacitance at the IN pin is approximately 0.5pF. Refer to the MAX3665 data sheet for more information.

Table 1. Connections, Adjustments, and Control

| CONTROL | DESCRIPTION |
|------------|---|
| VCC | Supply Voltage Connection (+3.3V or +5V, 100mA current limit) |
| +15V | Supply Voltage Connection for Photodiode Emulator Circuit (+15V, 25mA) |
| GND | Connection for Ground |
| JU1 | When shunted, the photodiode emulation circuit is active. This is a convenient location to measure the emulated photodiode current. |
| JU2 | Test Pin. Shunting JU2 disables the MAX3665 DC cancellation amplifier. |
| R5 | Potentiometer. Fine adjustment of the DC current input. |
| R7 | Potentiometer. Coarse adjustment of the DC current input. |
| OUT+, OUT- | Connections for the MAX3665 Output Signal |
| INPUT | Input Connection for a Signal Generator |

MAX3665 Evaluation Kit

Evaluates: MAX3665

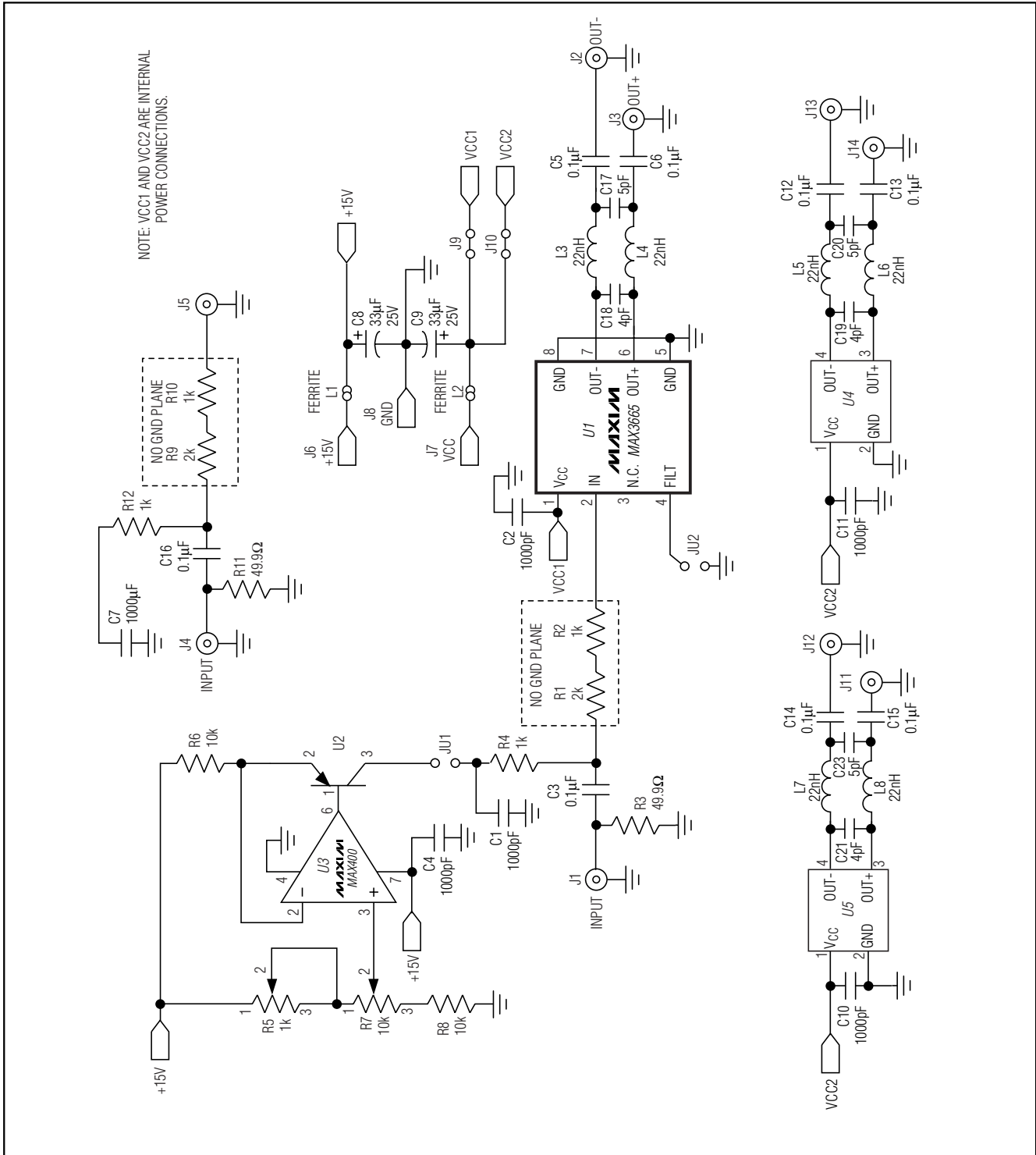

Figure 1. MAX3665 EV Kit Schematic

MAX3665 Evaluation Kit

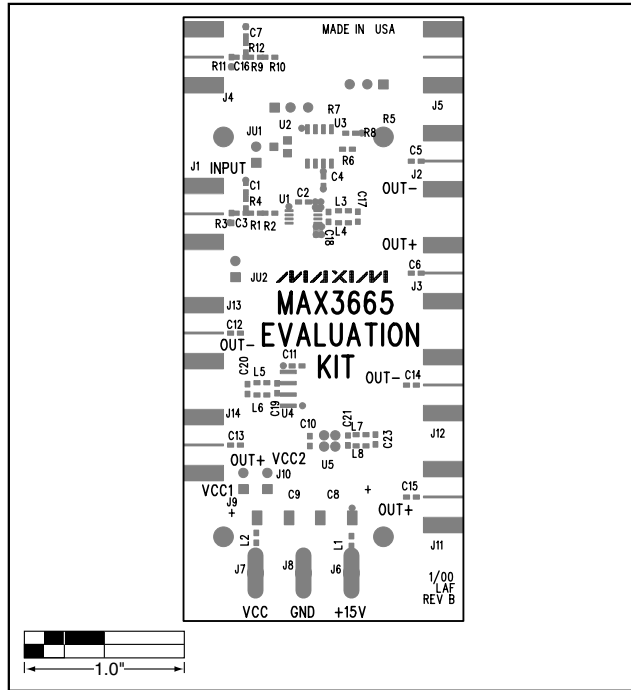

Figure 2. MAX3665 EV Kit Component Placement Guide

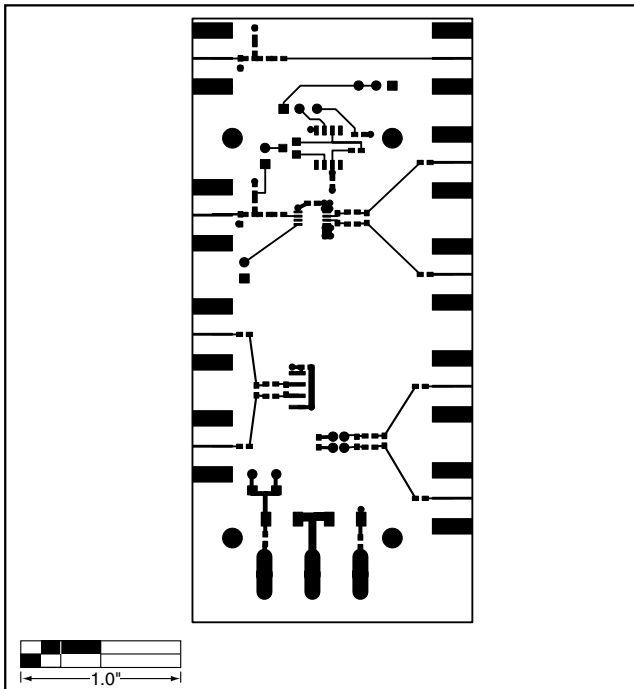

Figure 3. MAX3665 EV Kit PC Board Layout—Component Side

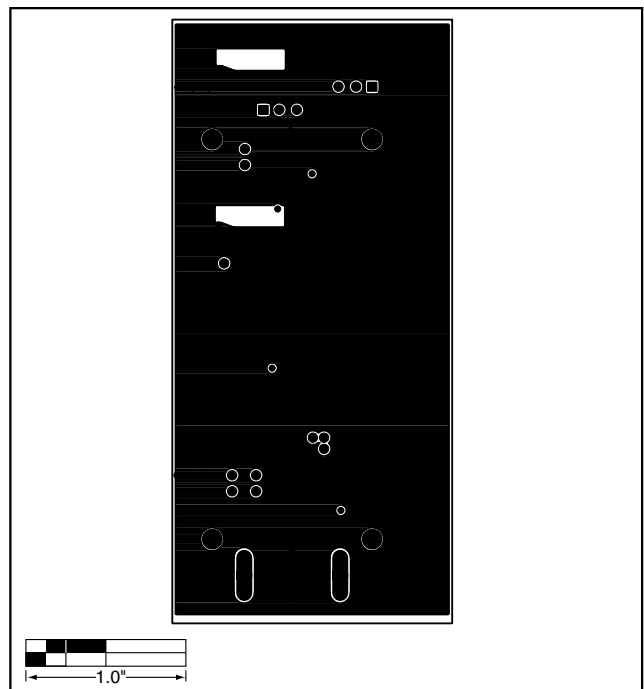

Figure 4. MAX3665 EV Kit PC Board Layout—Ground Plane

MAX3665 Evaluation Kit

Evaluates: MAX3665

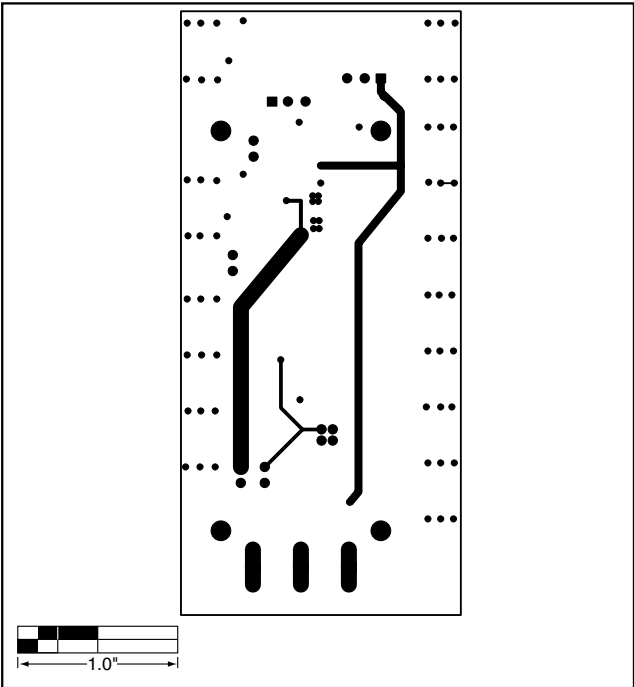

Figure 5. MAX3665 EV Kit PC Board Layout—Power Plane

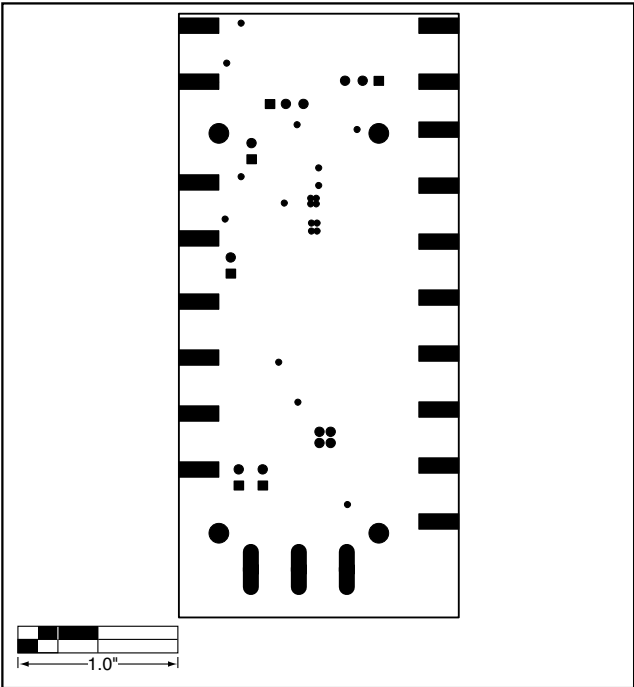

Figure 6. MAX3665 EV Kit PC Board Layout—Solder Side

MAX3665 Evaluation Kit

Evaluates: MAX3665

NOTES

Maxim cannot assume responsibility for use of any circuitry other than circuitry entirely embodied in a Maxim product. No circuit patent licenses are implied. Maxim reserves the right to change the circuitry and specifications without notice at any time.

6 _____ **Maxim Integrated Products, 120 San Gabriel Drive, Sunnyvale, CA 94086 408-737-7600**